



RoHS Compliant
2002/95/EC



Halogen Free

REV.	ECN. NO.	APPD.

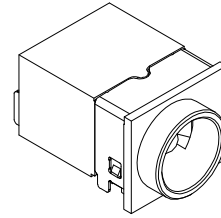

DIMENSIONS

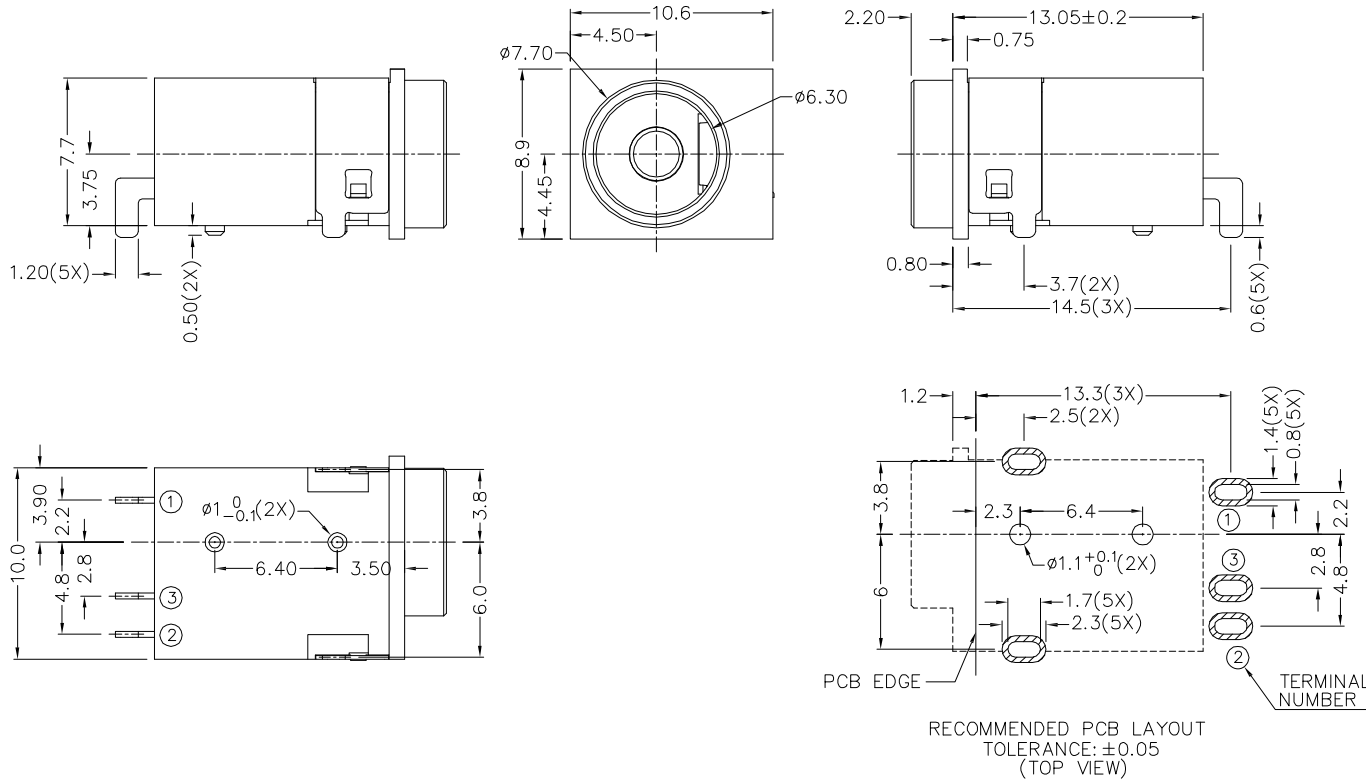

MODEL CODE:
 DCT0-1002HS- A □ 10 BK G 0 1
 (1) (2) (3)(4)(5) (6)(7)(8) (9)

(1):Series type:WATERPROOF DIP DC POWER JACK.
 (2):Series No.
 (3):Schematic option: A
 (4):Center pin diameter:
 H=φ2.0mm,J=φ2.5mm
 (5):Material of housing:
 10=PA10T
 (6):Housing color:
 BK=Black
 (7):Terminal plating:
 G=Gold(Au)
 (8):Special option:
 0=No special option
 (9):Packing mode:
 1=Reel packing

Specification:
 1.Rating :5A/16V DC Max.
 2.Contact resistance:≤30mΩ
 After test:≤60mΩ
 3.Insulation resistance:≥100MΩ (500VDC).
 After test:≥50MΩ
 4.Withstanding voltage:500VAC.
 5.Insertion and extraction force:0.3~3Kgs.
 6.Life test:5,000 cycles min.
 7.Operation temperature range:-25°C~85°C

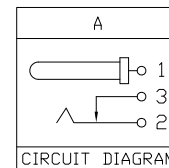

MODEL NO.	H	J
CENTER PIN	φ2.0±0.05mm	φ2.5 ^{+0.1} _{0.0} mm

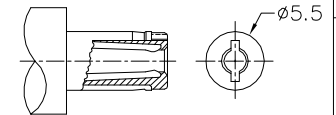

DC MATE PLUG

Bill of materials:

7					.X ±0.20	UNITS	mm
6	COVER	HIGH TEMP. PLASTIC	1		.XX ±0.10	MAT'L	
5	HOUSING	HIGH TEMP. PLASTIC	1		.XXX ±0.05	SEE NOTE	
4	SHIELD	BRASS	1			FINISH	
3	TERMINAL 3	BRASS	1			SEE NOTE	
2	TERMINAL 2	COPPER ALLOY	1			Q'TY	
1	TERMINAL 1	BRASS	1				
NO	PARTS	MATERIAL	QTY	FINISHING			

THESE DRAWINGS AND SPECIFICATIONS ARE THE PROPERTY OF ACCURATE INNOTECH INC AND SHALL NOT BE REPRODUCED, COPIED OR USED IN ANY MANNER WITHOUT THE PRIOR WRITTEN CONSENT OF ACCURATE INNOTECH INC.

雅安科技有限公司 ACCURATE INNOTECH INC.			
TITLE: WATERPROOF DIP DC POWER JACK		PART NO.: DCT0-1002HS	
DR: <i>Ricky</i> 2021/09/30		DWG NO.: AT0-1002HS	
CHKD: <i>Ricky</i> 2021/09/30		SCALE	SHEET
APPD:		3:1	1/2
		REV. B	CUSTOMER DRAWING



RoHS Compliant
2002/95/EC



Halogen Free

REV.	ECN.	NO.	APPD.

DIMENSIONS

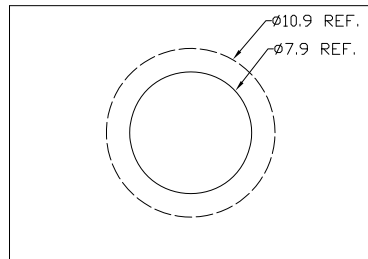

Top View

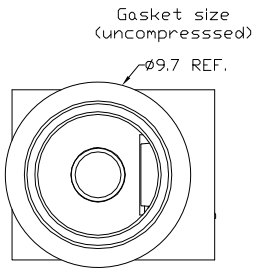
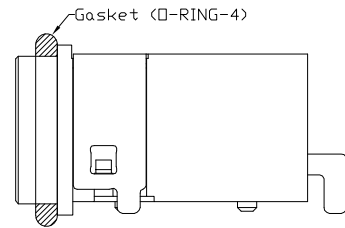
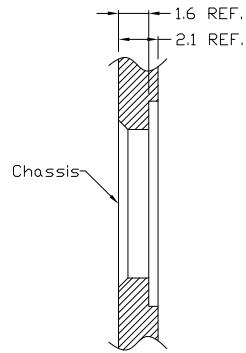

Gasket size (uncompressed)

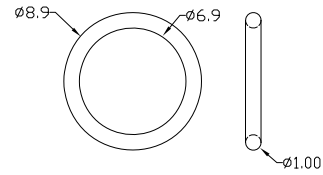

*Recommended Waterproof Gasket
Gasket Part No: O-RING-4

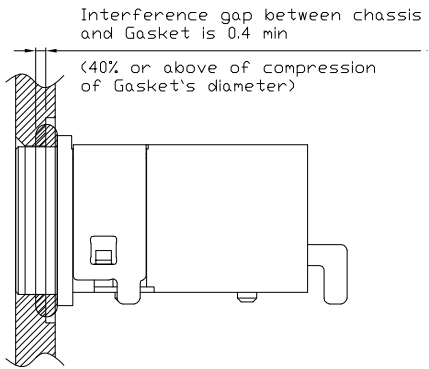

After assembling on chassis

.X	±0.20	UNITS	mm	雅安科技有限公司 ACCURATE INNOTECH INC.					
.XX	±0.10	MAT'L	SEE NOTE						
.XXX	±0.05	FINISH	SEE NOTE	TITLE:	PART NO.:				
THESE DRAWINGS AND SPECIFICATIONS ARE THE PROPERTY OF ACCURATE INNOTECH INC AND SHALL NOT BE REPRODUCED, COPIED OR USED IN ANY MANNER WITHOUT THE PRIOR WRITTEN CONSENT OF ACCURATE INNOTECH INC.				WATERPROOF DIP DC POWER JACK	DCT0-1002HS				
				DR: <i>Ricky</i> 2021/09/30	DWG NO.:				
Q'TY		CHKD: <i>Ricky</i> 2021/09/30		AT0-1002HS		SCALE	SHEET	REV.	CUSTOMER
		APPD:		3:1	2/2	B	DRAWING		