

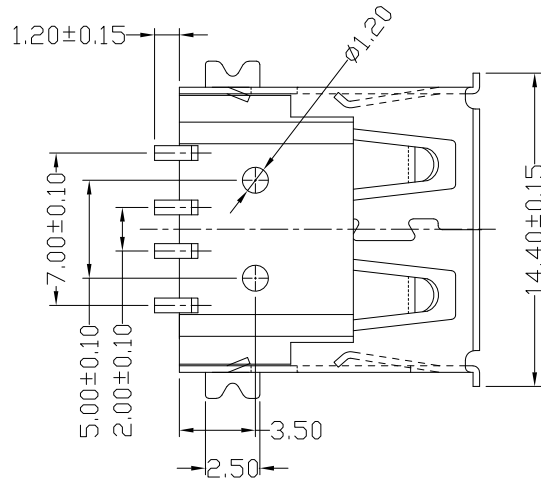

RoHS
Compliant
2002/95/EC

REV.	ECN.	NO.	APPD.

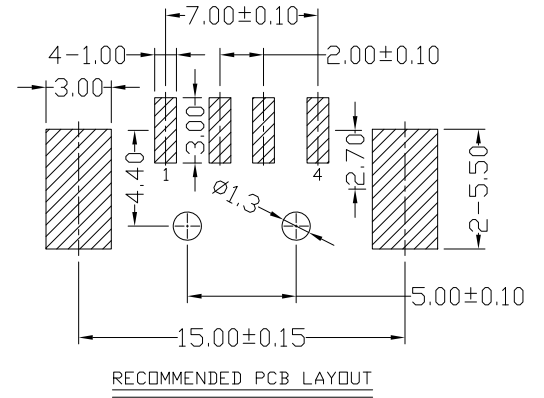
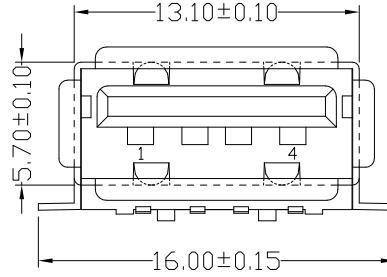
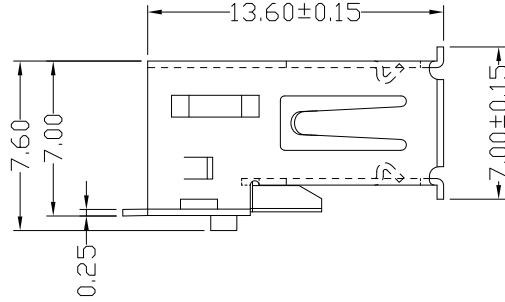

NOTES:

1.ELECTRICAL:

- 1)VOLTAGE CURRENT RATING: 1.5AMP,30V DC;
- 2)INSULATION RESISTANCE: 1000MΩ MIN;
- 3)CONTACT RESISTANCE: 30mΩ MAX;
- 4)WITHSTANDING VOLTAGE: 500V AC FOR 1MINUTE;
- 5)OPERATING TEMPERATURE: -55°C TO +85°C.

2.MECHANICAL:

- 1)MATING FORCE: 35N MAX.
- 2)UNMATING FORCE: 10N MIN.

3.DIMENSIONS MARKED "▼"

TO BE CHECKED BY Q.C & IPQC.

USAF-041N-4*VJ59

- 1:Au 1U'
- 6:Au 30U'
- W:WHITE
- B:BLACK
- 1:PBT
- 2:PA6T
- 3:PA9T
- 4:LCP

Bill of materials:

6					X.	±0.25	X'.	±5'	UNITS	mm	雅安科技有限公司 ACCURATE INNOTECH INC.								
5					.X	±0.20	.X'	±2'	MAT'L										
4					.XX	±0.15	.XX'	±1'	SEE NOTE										
3	SHELL	COPPER ALLOY	1	PLATED NICKEL	.XXX	±0.10	.XXX'	±0.5'	FINISH										
2	TERMINAL	COPPER ALLOY	4	PLATED GOLD/TIN					SEE NOTE										
1	HOUSING	LCP+30%GF	1	UL94V-0					Q'TY										
NO	PARTS	MATERIAL	QTY	FINISHING	THESE DRAWINGS AND SPECIFICATIONS ARE THE PROPERTY OF ACCURATE INNOTECH INC AND SHALL NOT BE REPRODUCED, COPIED OR USED IN ANY MANNER WITHOUT THE PRIOR WRITTEN CONSENT OF ACCURATE INNOTECH INC.						TITLE: USB AF 鱼叉脚贴板 有边 内弹1.2柱	PART NO.: USAF-04XN-4XVJ59							
											DR:	Ricky 2026/04/25	DWG NO.:	AII-VJ59					
											CHKD:	Ricky 2026/04/25	SCALE	1:1	SHEET	1/1	REV.	B	CUSTOMER DRAWING



RoHS
Compliant
2002/95/EC

REV.	ECN.	NO.	APPD.

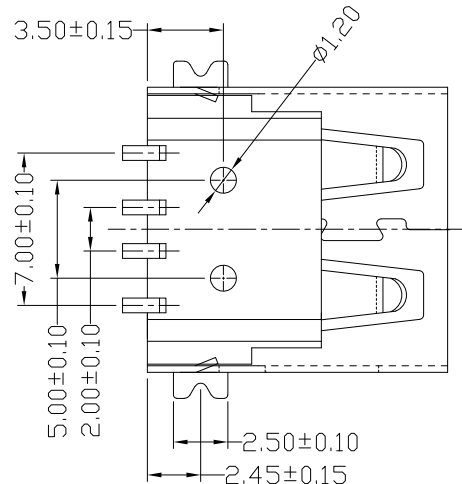
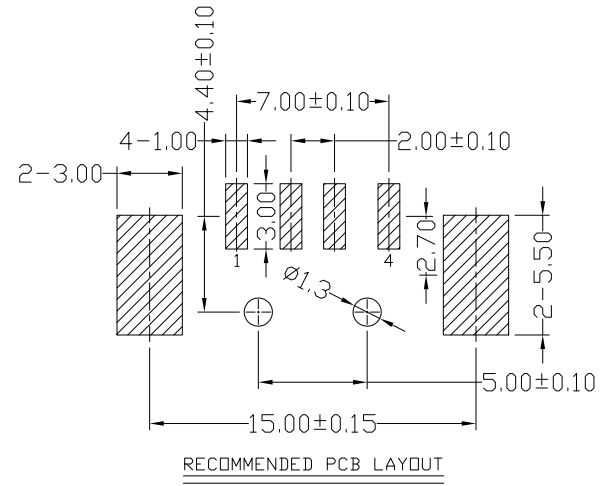
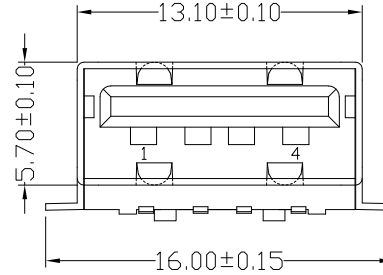
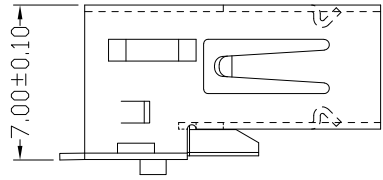

NOTES:

- ELECTRICAL:
 - VOLTAGE CURRENT RATING: 1.5AMP,30V DC;
 - INSULATION RESISTANCE: 1000MΩ MIN;
 - CONTACT RESISTANCE: 30mΩ MAX;
 - WITHSTANDING VOLTAGE: 500V AC FOR 1MINUTE;
 - OPERATING TEMPERATURE: -55°C TO +85°C.
- MECHANICAL:
 - MATING FORCE: 35N MAX.
 - UNMATING FORCE: 10N MIN.
- DIMENSIONS MARKED "▼"
TO BE CHECKED BY Q.C & IPQC.

USAF-041N-4*VJ591
 1:Au 1U*
 6:Au 30U*
 W:WHITE
 B:BLACK
 1:PBT
 2:PA6T
 3:PA9T
 4:LCP

Bill of materials:

6					X.	±0.25	X'.	±5'
5					.X	±0.20	.X'	±2'
4					.XX	±0.15	.XX'	±1'
3	SHELL	COPPER ALLOY	1	PLATED NICKEL	.XXX	±0.10	.XXX'	±0.5'
2	TERMINAL	COPPER ALLOY	4	PLATED GOLD/TIN				
1	HOUSING	LCP+30%GF	1	UL94V-0				
NO	PARTS	MATERIAL	QTY	FINISHING				

THESE DRAWINGS AND SPECIFICATIONS ARE THE PROPERTY OF ACCURATE INNOTECH INC AND SHALL NOT BE REPRODUCED, COPIED OR USED IN ANY MANNER WITHOUT THE PRIOR WRITTEN CONSENT OF ACCURATE INNOTECH INC.

UNITS	mm	雅安科技有限公司 ACCURATE INNOTECH INC.			
MAT'L	SEE NOTE				
FINISH	SEE NOTE	TITLE:	PART NO.:		
Q'TY	SEE NOTE	USB AF 鱼叉脚贴板 无边 内弹1.2柱		USAF-04XN-4XVJ591	
		DR:	AII-VJ591		
		CHKD:	SCALE SHEET REV. CUSTOMER 1:1 1/1 B DRAWING		
		APPD:	DRAWING		